



TECHNICAL SHEET

IQ SOFT

Smart softener



- Programming the device can be done via your smartphone.
- Monitor your water softener and water usage from a distance.
- Receive an alert when your salt needs refilling.





IQ SOFT

Smart softener
9L / 12L / 18L / 25L



Our IQsoft water softener is the most advanced solution for tackling hard water.

A compact footprint and state-of-the-art design combine to make IQsoft softeners a major breakthrough in the water treatment industry. No other softener comes close to matching its high-end specification, ease of installation or soft water benefits.

Monitor your water usage via your smartphone.

While our IQsoft softener is giving you perfectly softened water, its Wi-Fi technology can provide peace of mind by monitoring your water usage and managing your softener via smartphone or tablet. If you are planning a holiday, the Erie Connect App features a 'holiday mode' to avoid unnecessary consumption of water while you are away. Our IQsoft water softener is the most advanced solution for tackling hard water.

FEATURES

- ◆ Multilingual, two-line, legible display
- ◆ Easy programming, with all settings, except hardness and time, factory-set
- ◆ Integrated handles make for simple and easy installation
- ◆ Fully equipped with all necessary accessories
- ◆ Ultra-compact footprint allows installation even in the narrowest locations (width 28cm, depth 44cm)
- ◆ LED illumination of brine tank
- ◆ High efficiency up-flow regeneration with proportional brining, holiday mode and resin ageing correction
- ◆ Salt alarm
- ◆ Wi-Fi connectivity

BENEFITS

- ➔ User-friendly with the optimal readability of settings and statistics
- ➔ Plug and play - pre-set to perform at its best
- ➔ Ergonomic and suitable for installation even in the smallest of spaces
- ➔ Simplified salt load operation even in low ambient light
- ➔ Exceptionally low rinse water usage per regeneration leads to minimal salt consumption, with up to 40% salt-saving compared to standard softeners
- ➔ Unique technology measures the ageing of the resin to always obtain the most accurate capacity
- ➔ Holiday mode avoids unnecessary regeneration, resulting in reduced water and salt consumption during periods of absence, while maintaining the resin bed in optimal condition for service
- ➔ Professionals can remotely monitor the softener from the dealer web portal
- ➔ Wi-Fi softener connectivity via smartphone app with notifications and alerts on water and salt consumption



INTRODUCING THE DEALER WEB PORTAL FOR IQ SOFT CUSTOMERS!

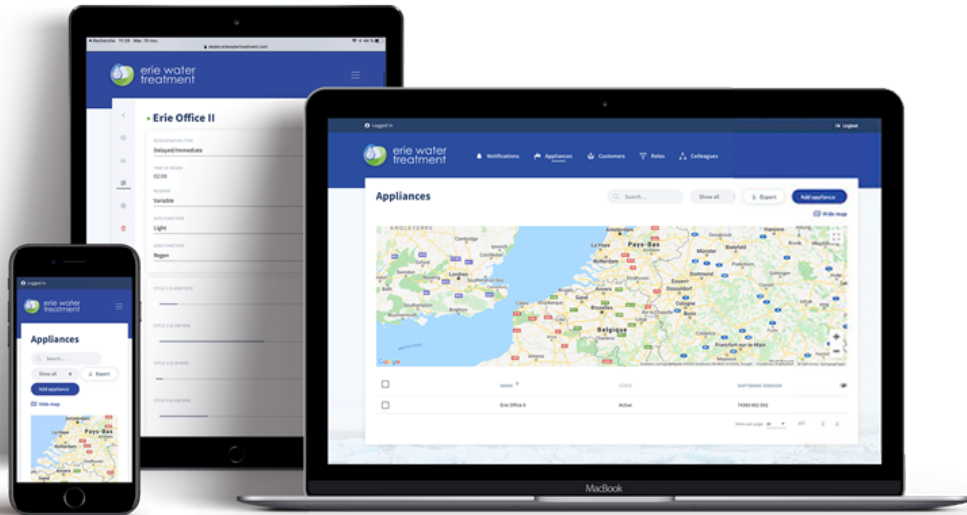

We would like to remind you the implementation of our new **Dealer Web Portal** launched on November 30th, 2020.
<https://dealer.eriewater.com>

Designed to get the most out of the product and to give our dealers optimal support, the Dealer Web Portal allows dealers to monitor and service their customer installations online, allowing remote management of the equipment through any laptop, tablet or smartphone with internet connection.

The entire management is in the dealer's 'online' hands. Please note that this new web portal is specifically intended for IQ SOFT customers.

If you have questions about the portal, please do not hesitate to contact us on eridealerportal@pentair.com.

CUSTOMER BENEFITS



ALWAYS VIGILANT AND INFORMED



UNIQUE 2-WAY COMMUNICATION



EASY TO USE



SAVE TIME, SAVE MONEY



EXTENSIVE SERVICING POTENTIAL



GEOLOCALIZATION OF ALL EQUIPMENT



IMPROVED CUSTOMER AND DATA MANAGEMENT

TECHNICAL SPECIFICATIONS

CHARACTERISTICS	IQ SOFT CS micro 0913	IQ SOFT CS mini 0916	IQ SOFT CS midi 0922	IQ SOFT CS maxi 0930
Part number	4035296	4035297	4035298	4035299
Resin volume (L)	9 L	12 L	18 L	25 L
Number of people	1-2	3-4	5-6	7-8
Nominal flow rate (m ³ /h) (residual hardness 0°f)	0,5 m ³ /h	0,7 m ³ /h	1,1 m ³ /h	1,5 m ³ /h
Nominal flow rate (m ³ /h) (residual hardness 5-10°f)	0,6 m ³ /h	0,9 m ³ /h	1,3 m ³ /h	1,8 m ³ /h
Peak flow rate (m ³ /h) (residual hardness 5-10°f)	0,9 m ³ /h	1,2 m ³ /h	1,8 m ³ /h	2,5 m ³ /h
Salt dosage g/resin (standard settings)	125 g/l	125 g/l	125 g/l	125 g/l
Salt consumption per regeneration (kg)	1,1 kg	1,5 kg	2,2 kg	3,1 kg
Water consumption per regeneration (L)	42 L	48 L	77 L	99 L
Softener capacity °f x m ³	31,5 °f • m ³	54,0 °f • m ³	91,8 °f • m ³	127,5 °f • m ³
Capacity in m ³ for 30°f inlet water hardness and 10°f residual hardness setting	2,3 m ³	3,0 m ³	4,5 m ³	6,4 m ³
In / out connections	3/4" BSPT	3/4" BSPT	3/4" BSPT	3/4" BSPT
Drain connection	1/2" hose	1/2" hose	1/2" hose	1/2" hose
Tank size	9x13	9x16	9x22	9x30
Accessories included	Plastic bypass, with incorporated mixing valve - 0,25 L resin cleaner - Universal hardness test kit, single bottle, °f/°d - Voltage transformer 230-24V - 3/4 BSP male in/out connection kit - 3 mtr reinforced drain hose with 2 clamps - Air gap with double drain connection			
Regeneration type	Upflow 5 cycles with proportional brinig			
System interface	Electronic display, wifi connectivity with Erie connect app & Dealer webportal			
Salt compartment capacity in kg	13,0 kg	17,0 kg	23,0 kg	35,0 kg
Product width	280,0 mm			
Product height	497,0 mm	575,0 mm	728,0 mm	982,0 mm
Product depth	438,0 mm			
Product depth with bypass assembled	540,0 mm			
Product weight	16,0 kg	21,0 kg	27,0 kg	36,0 kg
Packaging dimension (WxLxH) mm	400 x 480 x 680	400 x 480 x 680	470 x 320 x 760	470 x 302 x 1020
Quantity per pallet	12	12	14	14
Pallet dimensions (WxLxH) mm	120 x 100 x 153	120 x 100 x 153	120 x 100 x 167	120 x 100 x 220

Note: All calculations are based on a salt dosage setting standard of the PCB. The softener installation takes into account a pre-filter made of a 10" filter housing (Pentair ref. 150543) and a 10" 100micron Wound cartridge (Pentair ref. WWP100P10).

* Indicatives data. Maximum flow rate to produce in order to respect the required service velocity for an optimal ion exchange upon resin manufacturers recommendation, regardless of the inlet pressure.

** Values may vary upon local condition and programming. All consumptions are given for an inlet pressure of 3 bar.



ACCESSORIES

- ◆ Plastic bypass, with incorporated mixing valve
- ◆ 0,25 L resin cleaner
- ◆ Universal hardness test kit, single bottle, °f/°d
- ◆ Voltage transformer 230-24V
- ◆ ¾ BSP male in/out connection kit
- ◆ 3 mtr reinforced drain hose with 2 clamps
- ◆ Air gap with double drain connection

OUTLINE DRAWINGS

IQ SOFT Water softener 25L

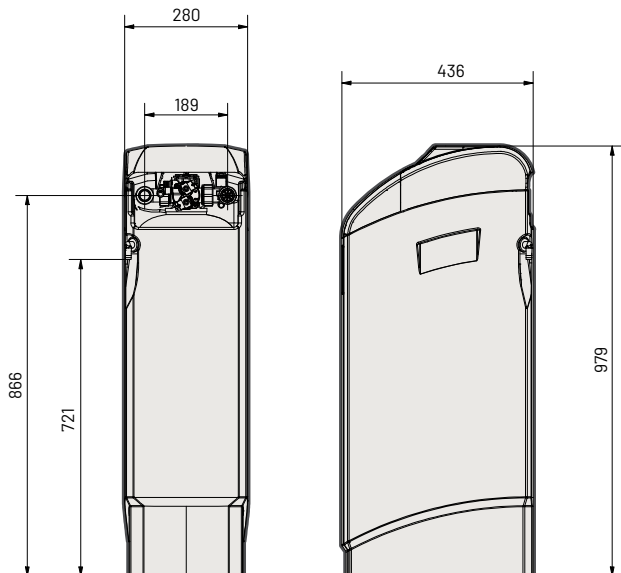

IQ SOFT Water softener 18L

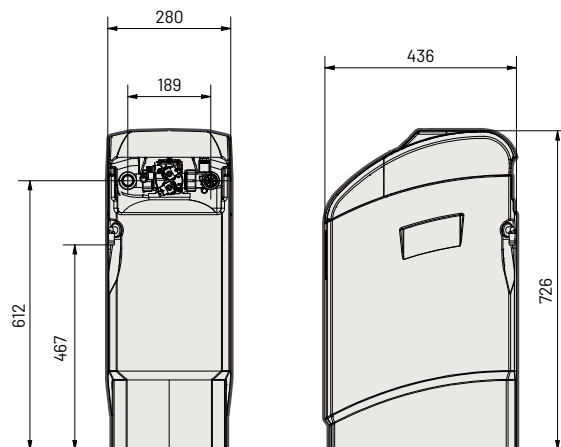

IQ SOFT Water softener 12L

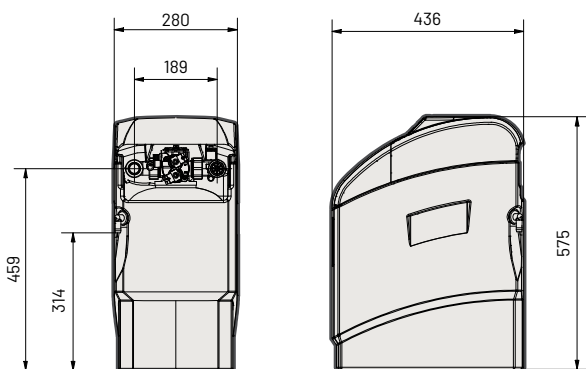

IQ SOFT Water softener 9L

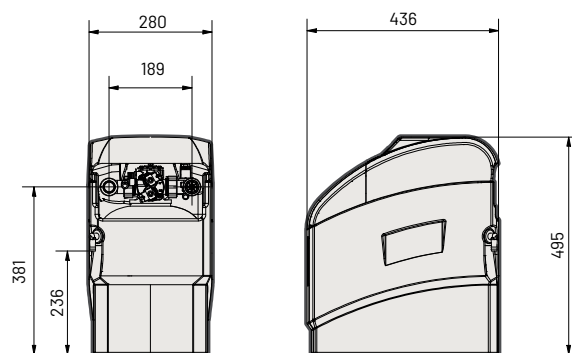



www.pentair.eu

All indicated Pentair trademarks and logos are property of Pentair. Third party registered and unregistered trademarks and logos are the property of their respective owners.

MKT-TS_136-EN-B © 2022 Pentair. All rights reserved.